



June 26, 2013

---

## **Electrical Design Standards for Electronics to be used in Experiment Apparatus at Fermilab**

These electrical design standards are to assist the system designer during the early stages of the experiment electronics design. In addition, they are used by Fermilab appointed reviewers during the safety inspection of experiment electronics installations. These standards have been gleaned from experience as well as from several other sources (see references). The application of these standards early in the design process can lead to simpler and safer designs. It can also speed the approval process for the Operational Readiness Clearance for Experiments which is required prior to the operation of an experiment.

Commercially available crate-based electronics systems (CAMAC, NIM, VMEbus, xTCA, Compact PCI, etc.) have been developed in accordance to available standards (IEEE, etc.) and will not, in general, be reviewed. The installations of these systems will be inspected and must meet accepted standards. It is important to note, however, that the non-standard (custom) use of these crate systems must follow these standards. All custom systems will be reviewed.

Fermilab encourages collaborators to discuss design issues as early as possible and throughout the design cycle. We are happy to hear from you and stand ready to assist you in your design effort. Questions should be directed to your Experiment's Liaison or the Chair of the Engineering Standards Committee. Their phone numbers are available on the Fermilab Web page.

### **Overcurrent Protection Devices**

Either fuses or resettable positive temperature coefficient (PTC) devices may be used for overcurrent protection of conductors and/or printed circuit boards. Whichever device is used must be sized and applied per the manufacturers recommendations and must have an interrupting current rating greater than the maximum fault current available in the circuit.

### **Over-current Protection for Printed Circuit Boards**

A fuse is required for each voltage that is capable of delivering enough power to damage the board in the event of a short circuit. The fuse should be located electrically between the power pins and the components on the card. For multilayer printed circuit cards, pins that distribute power at the same voltage level should be connected to a common section of the power plane, separate from the rest of the power plane. The fuse should then be used to connect this isolated section with the remainder of the plane. The fuse rating should be high enough to handle the inrush current at power-up yet small enough to blow before an over-current situation causes damage to the board or components on the board (beyond the cause of the over-current condition.) Do not install fuses in parallel.

## Over-voltage Protection for Printed Circuit Boards

A Transient Voltage Suppressor (TVS) is required to address the situation where a power supply goes out of regulation or an accidental, external connection causes a voltage that is higher than the acceptable maximum to be presented to the power connections of the printed circuit board. A TVS must be wired in parallel with the load being protected, and on the load side of the fuse. Each of the various voltage planes should have its own TVS installed between the voltage plane and ground. Should the power supply cause a voltage excursion above the TVS's clamp voltage, the TVS will conduct at the clamp voltage. This will cause a large current to flow through the fuse, thereby causing the fuse to blow. After the fuse blows the card is no longer in danger of being damaged by the over-voltage condition. If the transorb that is used in the design is selected carefully, by taking into account the fuse value and operating voltage, the transorb should not be damaged in an over-voltage incident. The intent is to limit the damage that results from an over-voltage condition to that of several blown fuses in a crate. This is certainly preferable to components being destroyed and, in the worst case, catching fire. However, it also means that provisions must be made to be able to replace blown fuses in an efficient manner so as to minimize the down-time of the experiment.

Silicon Avalanche Diodes (SADs) are good choices for this application, such as the Vishay SMBJ series. These are very fast acting. One must choose the SAD carefully so that the conduction curve of the device works properly with the trip curve of the fuse. Other types of TVS devices include Metal-Oxide Varistors (bidirectional, typically for AC line protection), SIDACTors (bidirectional and low capacitance, used in Datacom and Telenetworking), Gas Plasma Arrestors (communication and signaling equipment), and spark gap devices.

## Powering Printed Circuit Cards

For multilayer printed circuit boards it is common practice to utilize a layer of copper foil for power distribution and another layer for ground return. The connector manufacturer will rate a connector pin for the maximum current that it can carry. Pins may be connected in parallel when a greater amount of current is required than one pin can carry. However, the current carrying capacity of each pin must be derated. This is to account for the fact that, due to differences in the resistance of the paths (which include the pins), an unequal amount of current will flow through the various pins. The pin that is in the lowest resistance path will carry a greater portion of the total current than a pin in a path with higher resistance. The total current will be determined by the load presented by the circuit board. If the system is implemented in a fashion that requires all pins to carry the maximum rated current then some pins will carry a greater amount of current than is allowable because some pins will carry less due to their higher resistance. A rule of thumb is to use 2/3 capacity, i.e., a single pin rated at 3 amps may be considered to handle 2 amps when multiple pins are in parallel. Boards powered in this fashion should not be plugged in "live" because the first pin making contact must handle all the current.

Using multiple pins in parallel to supply power to a multilayer printed circuit board requires special considerations for fusing. One approach separates the voltage layer into two parts, one of which is connected to the power pins on the connector and the other is connected to the components. The two parts of the voltage plane are connected by a fuse. See Figure 1. (Note that a transient-voltage-suppressor is not shown.)

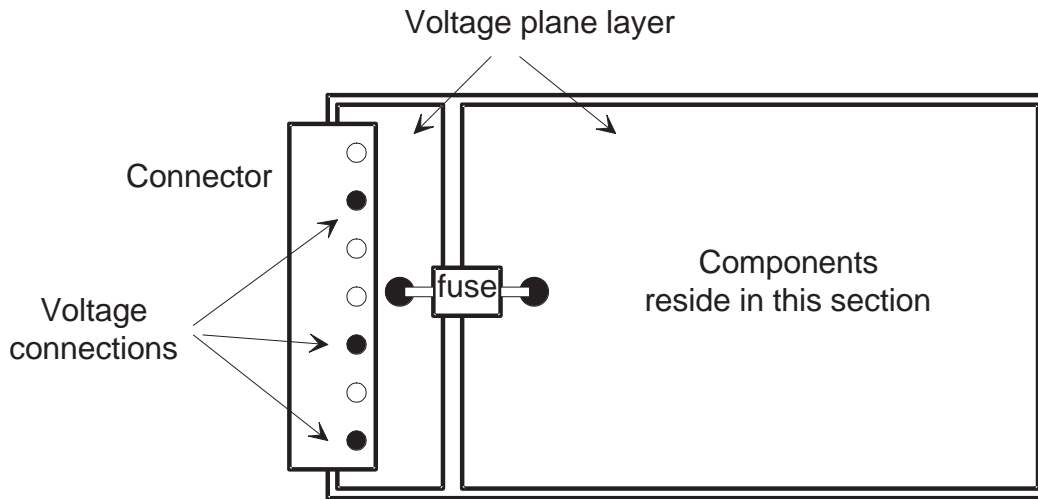

Connector pins that carry the power to the circuit board are connected to the portion of the voltage plane layer that is directly under the connector. Current for the components on the circuit board flows through the fuse.

**Figure 1.**

An alternative is to divide the power layer into separate sections with each section supplied by its own pin. Since no current sharing takes place one does not need to derate the current carrying capacity. However, each section would need to be separately fused and protected against over-voltage with individual transient-voltage-suppressors.

Special consideration is required for making soldered connections between the power/ground layers and pins. The term “thermal” refers to the portion of the foil layer of a power/ground plane where the connection is made to a pin. Heat that is applied to a pin which is in contact with the copper layer will be drawn away by the relatively large thermal mass of the layer. As a means to thermally (but not electrically) isolate the hole from the rest of the layer some of the copper outside the perimeter of the hole is etched away in the fabrication process leaving a few radial paths of copper to make the electrical connection from the pin to the foil layer. If pins are connected to the power plane using thermals then the thermal must be able to carry the required current without excessive local heating. Note that if heating is taking place at the connector between the pin and the board while the board is operating then there is probably an excessive voltage drop.

### Ground Returns

To keep the inductance in a signal return path down to a reasonable value it is required that the designer ensure that an adequate number of pins are reserved for return signals. When many digital signals are changing simultaneously on the data or address lines on a circuit card a great deal of instantaneous current will flow through the ground pins. (Another occurrence that causes a great deal of current to flow is the refresh cycles on a board that is heavily populated with dynamic RAM memory.) Pins and traces act as inductors in parallel. With few pins, the inductance and current can be high enough to cause a significant shift in the voltage potential of the ground pins. As more pins are used for the ground returns the magnitude of the voltage shift is reduced. Wider traces will help reduce the inductance and decrease noise. A calculation should be done to determine the magnitude of voltage shift that can be expected.

### Wire Size for Power Distribution

Copper is the only conductor to be used. Table 1 tabulates the minimum wire size required for a given available maximum current (ampacity). This table has been derived from several sources and the ampacities are conservatively specified taking into account: bundled conductors, limited air flow and 30°C (86°F) ambient. Insulation material must be rated for 90°C (194°F) minimum. The use of this table will result in a conservative design for the typical environments seen in experimental areas. It reduce design difficulties if used early.

Conditions				
	Copper Temperature		75;C	167;F
	Ambient Temperature		30;C	86;F
SIZE in AWQ, MCM	AMPERES			
	Number of conductors bundled together			
	1 to 3	4 to 6	7 to 24	25 to 42
30	1.6	1.4	1.2	1.1
28	2.4	2.2	2	1.7
26	3.2	3	2.7	2.3
24	4.8	4.3	3.8	3.2
22	6.4	5.8	5	4.3
20	8	7	6	5
18	12	11	9	8
16	15	14	12	10
14	20	16	14	12
12	25	20	18	15
10	35	28	25	21
8	50	40	35	30
6	65	52	46	39
4	85	68	60	51
2	115	92	81	69
1	130	104	91	78
1/0	150	120	105	90
2/0	175	140	122	105
3/0	200	160	140	120
4/0	230	184	161	138
250	255	204	179	153
300	285	228	200	171
350	310	248	217	186
400	335	268	235	201
500	380	304	266	228

**Table 1.**

Higher temperatures or other unusual conditions may require larger wire size and/or different insulation material. Special conditions that may require conductors outside of those specified in Table 1 must be reviewed by Fermilab Division Safety personnel.

Table 2 is included since copper bus is often used for detector power distribution. Table 2 clearly shows that for any given cross-section there is a substantial temperature rise for higher currents. Consequently, the one square inch per 1000 amperes is the maximum recommended design parameter (see item “d” in the General Considerations section below). The temperature rise must be taken into account when designing the power distribution bus.

Size Inches	Cross-sectional Area		Weight per foot, pounds	DC Resistance, Micro ohms per foot	Skin Effect Ratio	60-Cycle Current rating, Amperes	
	Square inches	Cir. mils, thousands				30; C rise	65; C rise
1/8 x 7/8	0.1094	139.3	0.4226	76.46	1.00	220	360
1/8 x 1	0.125	159.2	0.483	66.9	1.00	240	400
1/8 x 1-1/2	0.1875	238.7	0.7245	44.6	1.01	340	560
1/8 x 2	0.25	318.3	0.966	33.45	1.02	440	720
1/8 x 2-1/2	0.3125	397.9	1.208	26.76	1.02	530	880
1/4 x 1/2	0.125	159.2	0.483	66.9	1.00	210	350
1/4 x 3/4	0.1875	238.7	0.7245	44.6	1.01	290	470
1/4 x 1	0.25	318.3	0.966	33.45	1.02	360	590
1/4 x 1-1/4	0.3125	397.9	1.208	26.76	1.02	430	710
1/4 x 1-1/2	0.375	477.5	1.449	22.3	1.03	500	820
1/4 x 1-3/4	0.4375	557	1.691	19.11	1.04	560	930
1/4 x 2	0.5	636.6	1.932	16.73	1.04	630	1050
1/4 x 2-1/2	0.625	795.8	2.415	13.38	1.05	750	1250
1/4 x 3	0.75	954.9	2.898	11.15	1.07	860	1450
1/4 x 3-1/2	0.875	1114	3.381	9.56	1.09	990	1650
1/4 x 4	1	1273	3.864	8.36	1.10	1100	1850
3/8 x 3/4	0.2813	358.1	1.087	29.73	1.02	370	610
3/8 x 1	0.375	477.5	1.449	22.3	1.03	460	750
3/8 x 1-1/4	0.4688	596.8	1.811	17.84	1.04	540	890
3/8 x 1-1/2	0.5625	716.2	2.174	14.87	1.05	620	1050
3/8 x 1-3/4	0.6563	835.6	2.536	12.74	1.06	700	1150
3/8 x 2	0.75	954.9	2.898	11.15	1.07	770	1300
3/8 x 2-1/2	0.9375	1194	3.623	8.92	1.10	920	1550
3/8 x 3	1.125	1432	4.347	7.43	1.12	1060	1750
1/2 x 1	0.5	636.6	1.932	16.56	1.04	550	910
1/2 x 1-1/4	0.625	795.8	2.415	13.24	1.05	650	1050
1/2 x 1-1/2	0.75	954.9	2.898	11.04	1.07	740	1200
1/2 x 2	1	1273	3.864	8.28	1.10	900	1500
1/2 x 2-1/2	1.25	1592	4.83	6.62	1.15	1070	1800
1/2 x 3	1.5	1910	5.796	5.52	1.18	1230	2050

Table 2.

### Ribbon Cable for Power Distribution

Ribbon cables can be a special problem when they are used to carry power supply currents. They are usually small gauge (28 AWG) and generally do not have 90°C insulation as required in these standards. For example, in many experiments, ribbon cables are used to provide power to printed circuit boards as well as carry signals, e.g., multiwire proportional chamber systems that use banks of Nanometric N277-C amplifiers. It is not unusual that the ribbon cables carry several amperes of current. A short circuit in any one printed circuit board could cause excessive current flow in the ribbon cable with the potential of cable overheating, insulation failure, and fire. To minimize this possibility, the following apply:

1. The length of all 28 AWG ribbon cables used for power distribution in excess of one (1) ampere shall be less than 15 feet long.

## Electrical Design Standards for Experiment Apparatus

2. The maximum current through any single conductor in the ribbon cable shall be limited to 2.4 amperes.
3. In applications where several (2 to 6) conductors in one ribbon cable are used in parallel to carry currents in excess of 3 amperes total, a maximum of 2.2 amperes per conductor is permitted. The limits of Table 1 must be applied for greater than 6 conductors.
4. Each parallel wire is to be bonded solidly together at the power supply and load connections so as to prevent one of the parallel wires from carrying more than its share of the load current.
5. In addition, misalignment of plugged in printed circuit cards could lead to excessive conductor current. Therefore, mechanisms to prevent such misalignment shall be employed.

### Remote Sensing for Power Supplies

In detector electronics systems, the “bulk” power supply is often located some distance from the electronics. Remote sensing is often used to minimize the deleterious effect that long power leads have on voltage regulation at the load. In most cases the sense wires are small in gauge, at least as long as the power leads and are connected from the load connection to the sense inputs on the power supply. If connected this way, and a short circuit inadvertently develops anywhere along their length, these wires will likely fail. Several methods are available to solve this problem, e.g., fuses or current limiting resistors can be installed at the load side sense connection as shown schematically in Figure 2. Sizing the sense wire to carry the total load current is a possible solution, but is not appropriate in most cases. Note that for most power supplies, shorted sense inputs results in increased output voltage and higher output current.

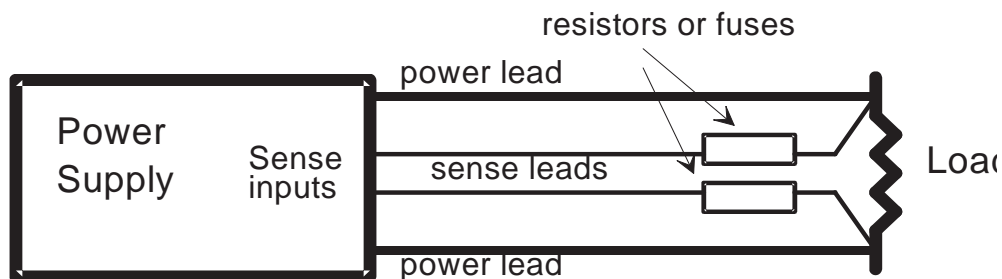

Figure 2.

### General Considerations for Power Distribution

- a. Splices should be kept to a minimum and preferably not used at all.
- b. All connectors, lugs, terminals, etc., must be of copper. Tinned copper is preferable. Stainless steel or silicon-bronze nuts and bolts are recommended for joining copper flags or lugs. Copper or brass bolts should not be used for power connections where greater than 50 amperes is possible.
- c. All wires should have strain relief at the connection points. Stud and lug connections are a special problem and should be restrained to prevent accidental rotation and a loose connection. Belleville washers can be of value with these connections.
- d. All current distribution bus shall be copper and have a cross section of at least one square inch per 1000 amperes (see Table 2), or be otherwise proven to have an acceptable temperature rise.

- e. All bolted connections shall have a contacting bus surface area of at least one square inch per 1000 amperes, or have an acceptable temperature rise.
- f. Bolted connections must have a contact pressure of 2000 pounds per square inch.
- g. Soldered connections should not be used for connections carrying greater than 50 amperes. Silver brazing is acceptable.
- h. The operating temperature of copper bus can easily reach 100°C (212°F). The bus operating temperature must be compatible with the insulation rating of the connected load cables. Note that any fuses used should be mounted away from a bus that operates at elevated temperature. Elevated fuse temperatures will cause premature fuse failure.

### Connections From the Power Supply to the Backplane

Any connector that is used in power distribution must be rated to carry the maximum current that may be presented either from the power supply itself or, if a fuse is located between the connector and the power supply, from the fuse. Additionally, the design of the connector should be such that it would require a significant amount of effort to accidentally short two of its conductors together. Note that when power connections are secured with a bolt or screw, the connection must be designed so that surfaces other than the bolt or screw can carry the rated current.

Copper bus bar used to distribute power along the backplane should be fabricated with a cross section that is large enough to ensure that either the current density is kept to under 1000 amps per square inch or the temperature rise is acceptable. Copper bus bar should be clean and flat to minimize the resistance of the connection.

When connecting a power supply to multiple crates all cables must be protected from the effects of a short. One way is to size the wire to safely carry the maximum current the power supply can output. When using wire that cannot safely carry the power supply's maximum current, a fuse is required to prevent the wire from overheating. An example is shown in Figure 3.

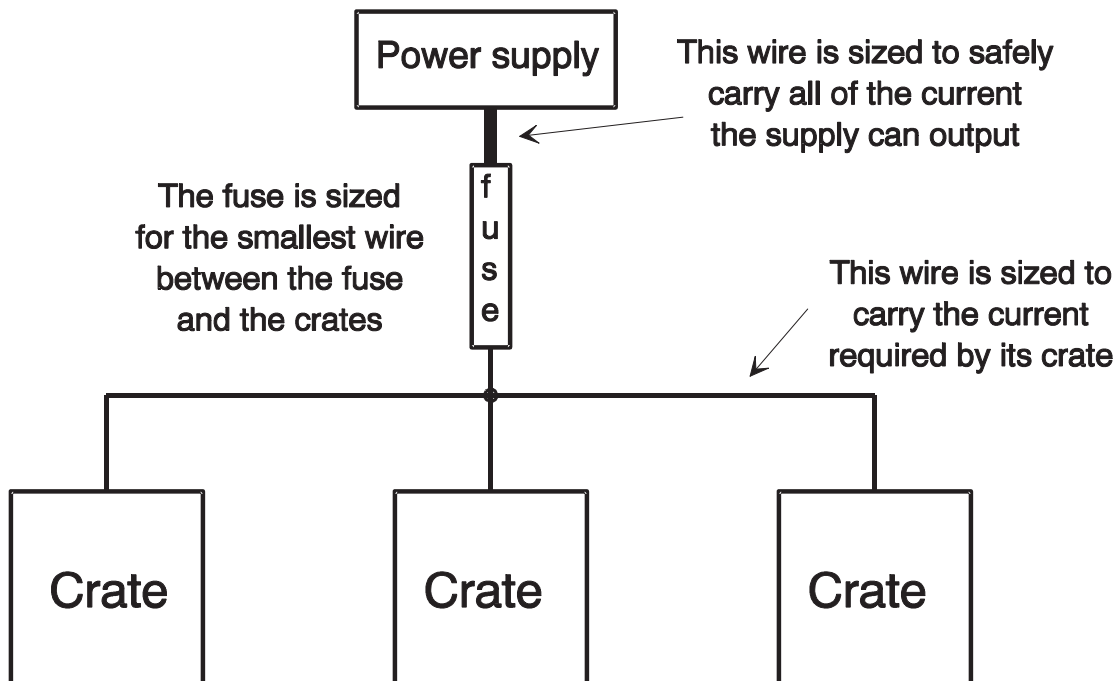

Figure 3.

A drawback to the approach shown in Figure 3 is that a short circuit in either of the crates causes all three crates to lose power when the fuse blows. An alternative approach, shown in Figure 4, addresses this issue by utilizing three fuses. The important point is that each wire in the power distribution system is protected from the possibility of overheating due to current flow which exceeds its capacity. Drawings of this type, which will include the power supply capacity, wire sizes, and fuse ratings, will be required to be provided for safety reviews.

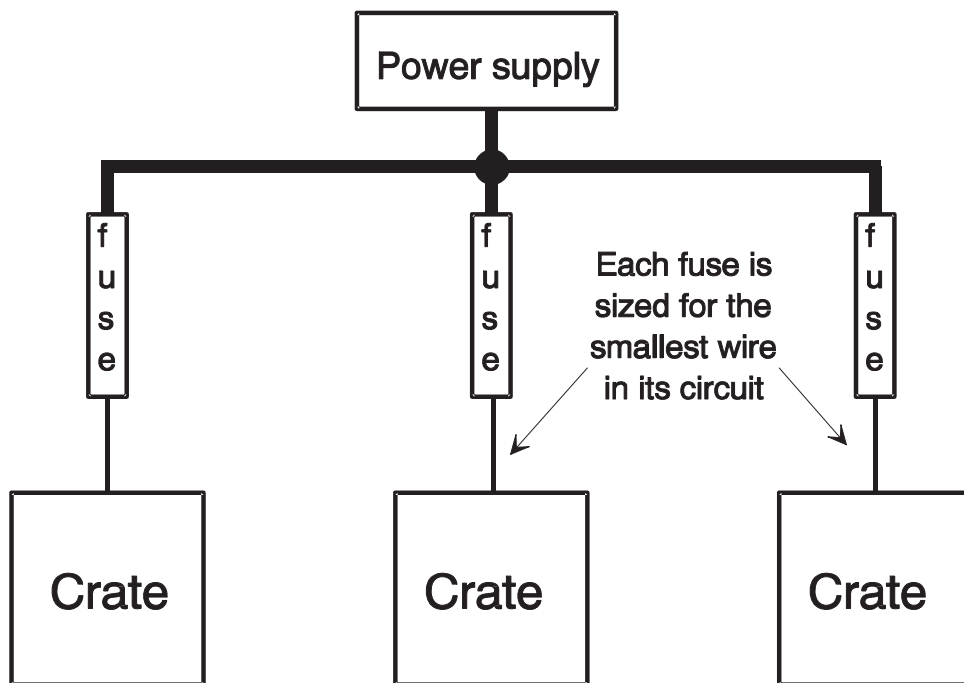

Figure 4.

### Power Dissipation of Printed Circuit Boards

As a “rule of thumb,” the power density of a circuit card should be limited to a maximum of 1/2 watt per square inch. Areas of the board may be allowed to have a greater power density but arrangements should be made to ensure that the heat is dissipated effectively and without inducing hot spots on other parts of the board or on adjacent boards.

### Cooling of Electronics Chassis

The use of natural convection to cool electronics is desirable. For greater heat loads, forced air cooling utilizing fans is the next choice. When the power density of the electronics is greater than what can reasonably be cooled with fans, then water-cooled heat sinks or air/water heat exchangers are utilized. However, water cooling increases the complexity of an installation and adds another source of problems during the operation of the experiment. The design should be such that the cooling fluid, be it air, water, or some other, should not vary more than 10°C over the area of the board. This is to keep the loss in noise immunity in the electronics, which is caused by difference in temperature, to a reasonable amount.

The temperature of the cooling water can become a problem. If the temperature of the water is below the dew point of the ambient air then water will condense and drip onto the electronics. The dew point is likely to be highest during the hot summer months, precisely when one needs the most cooling performance from the system. A goal is to have the electronics operate with the coolant between 30° and 40°C. This is adequate to prevent condensation in almost all cases and minimizes



the loss of noise margin due to large temperature differences between components with signal connections on the circuit boards being cooled.

Whichever system is chosen, good air flow is necessary in order to ensure that the cooling air passes over the electronic components that need to be cooled. When empty slots on the front of the crate are not covered by blank panels, the cooling air encounters a low impedance at the opening and a large percentage is forced out the front rather than up past the components on the upper portion of the cards. Install blank front panels on the front of empty card slots to alleviate this loss of cooling effectiveness.

For systems that require yet higher cooling performance one must consider that, even with blank front panels in place, the empty slots will present a lower impedance to the air flow than slots which have cards present. A greater volume of air will flow in the empty slots causing less air to flow in the occupied slots. An effective, though somewhat costly, solution is to populate the empty slots with dummy cards that present the same impedance to the flow of cooling air as the printed circuit cards do. This approach will not be required in most installations.

### **Rack Protection**

When there is a large investment in the cost of the equipment that will be in a rack and when the equipment is custom made (as opposed to off-the-shelf commercial electronics), a device to detect faults in the system and shut the system down when a fault occurs should be considered. A rough rule of thumb is that when custom electronics can be protected for 10% or less of its cost, then a rack protection system should be considered. Parameters that can be monitored include: temperature, smoke, voltage, cooling air flow, cooling water flow, condensation/water leakage, and current. Sophisticated rack protection systems have been fabricated for approximately \$2500 per rack. Systems that have a reduced set of parameters to monitor may cost less. Note that rack protection systems which monitor the voltage on high-current conductors must have the monitoring points protected from the hazard of an over-current situation caused by a short circuit on the monitoring wire.

### **I/O Connector Location**

An issue that often entails tradeoffs is the method of connecting I/O cables to the cards in a chassis. If the location of the connectors is the front panel of the cards then it is easy to get to the connector on a card in a sparsely populated chassis. However, if there are 26 cards in a chassis, with each having one or more cables running to it, the front of the chassis can become a jumble of cables. This creates a routing problem for positioning the cables themselves and additional problems with having enough room to remove the cables to a particular card, draw the card out of the chassis, replace the card, and then reconnect the cables.

If the location of the I/O connections is the back of the circuit board then provisions have to be made to make the connections. Some of the standard bus backplanes used at Fermilab do have provisions for this. Examples include VMEbus which has, as part of its specification, user-defined pins on the backplane which are not bussed but go straight through the backplane to a connector mounted on the back side of the backplane to which an I/O connector can be mated. This moves the challenge of cable routing to the back of the chassis and leaves the front open to easily remove and replace circuit boards since the I/O connector is actually mated to the back of the backplane and not to the circuit board being replaced. A combination of I/O connectors on the front and back can be employed when no other option is as attractive.

For systems that have large number cables which are densely packed together, the routing and physical support of the cables becomes a design challenge wherein the best solution is not always obvious. The location of densely packed cables impacts the flow of cooling air. Consideration for cable support and routing must be given very early in the system design cycle because of the resulting implications for printed circuit board layout and chassis configurations.

It is also possible to fabricate a custom backplane that utilizes the user-defined pins and electrically connects them from one card slot to another for the use of the boards in a specific system. Though the pins defined by the backplane specification remain unchanged, one must keep in mind that some commercial cards expect that the user-defined pins are available for their use and this could cause a conflict with the utilization of cards that were not designed specifically for the custom backplane.

### **Auxiliary Cards**

In this context, an auxiliary card is a printed circuit board that mounts on the backside of a backplane, at 90 degrees to the backplane, and is electrically connected to a card installed on the front side of the backplane.

Cooling can become a problem if the heat generated by the electronics on the auxiliary card is greater than what can be cooled by convection with air at the temperature in the rack. Fans and heat exchangers are commonly available for the cards mounted on the front side of the backplane but it is difficult to find cooling devices for the back side which, in most cases, is left open.

Providing power to the auxiliary cards can also be a challenge. Some of the backplane specifications do not have power available on the connector to which an auxiliary card will be attached. When the power pins are available, there may not be enough current capacity available from the pins to supply both the auxiliary card and its corresponding card on the front of the crate. Designing and fabricating a custom backplane and using the user-defined pins to bus power to the auxiliary cards is one solution, albeit an expensive one. However, one drawback to this approach is that any time one would like to power up the card for testing or other purposes, the card must be in a chassis that is equipped with the custom version of the backplane as opposed to the more commonly available standard version. This can become a very significant handicap when there are more people troubleshooting parts of the system than there are fully-configured test stands available.

Yet another option for powering an auxiliary card is a power connector mounted on the card and a dedicated cable bringing power from the power supply. This solution requires that the power cable be protected against over-current situations with a fuse and also requires careful routing of the power cable.

### **Keying Unique Cards and Slots**

When a variety of cards of the same form factor but differing functionality are used in the same backplane chassis, consider whether damage can result if one of the cards is powered up in a slot that is configured for a different card. If damage could result, then a keying system should be implemented for slots and cards to avoid inadvertently inserting a card in the wrong slot.

### **Design for Test**

The procedure for troubleshooting electronic systems is greatly enhanced by incorporating several features on printed circuit cards. Front panel LEDs that indicate the status of various module functions help to identify which card in a crate, or which subcircuit on a card, is not working

## Electrical Design Standards for Experiment Apparatus

properly. A circuit that is sometimes referred to as a “heartbeat” for modules that include a microprocessor utilizes a one-shot mono-stable multivibrator and an LED. The one-shot may be triggered by a software/firmware routine that executes periodically. The implication is that the processor is not running if the heartbeat LED is not illuminated.

Status registers that can be read out via computer can be utilized to troubleshoot individual boards as well as system problems.

Test points comprise nodes in the circuit that are wired to front panel connectors to which probes from test equipment can be attached in order to quickly determine the status a portion of the circuitry.

### Documentation

It is essential to have well-written documentation for the electronics system in order to ensure that the system can be reviewed, that it can be maintained, and that others can be trained to operate it in the shortest amount of time. Drawings that show the power distribution from power supplies to the crates will be required for safety reviews. Additional documentation should include accurate schematic diagrams, as-built drawings, and diagrams of interconnecting wiring. An operating manual should be written that describes how the system is to function. Well-documented source code files for programmable logic device (PLD) or field programmable gate arrays (FPGA) integrated circuits should be available.

Documentation that clearly describes the procedures for verifying the functionality of the circuit boards, and the system as a whole, should be written.

### References

Fermilab ES&H (Environment, Safety & Health) Manual section 5041, *Low Power Electrical and Electronics Safety*

Fermilab ES&H Manual section 5045, *High Voltage Coaxial Connectors*

Fermilab ES&H Manual section 5046, *Low Voltage, High Current Power Distribution Systems*

*MECL System Design Handbook, Fourth Edition*. Compiled by the Computer Applications Engineering Department of Motorola Semiconductor Products Inc. Author: William R. Blood, Jr. This is an excellent reference. Though it is oriented to Motorola’s emitter coupled logic, the content has taken on even greater relevance as other logic families have approached ECL in speed and power dissipation.

Investigation of the Fire in Experiment E-687 at Fermi National Accelerator Laboratory, October 3, 1987. Report from Fermilab Internal Investigation Committee.

Alpha Wire Corporation Full-Line Catalog W-10, © 1987

National Electrical Code - 1993

Fermilab internal memo, TM #1675, 2100.000, “Ampacity Tests of 28 AWG Ribbon Cables,” Erika Drennan, Research Division, E/E Department, April 1990

Overcurrent Protection in Electronics Systems, SLAC Committee Report SM 205, June 9, 1989